

selec

EM306/EM306-C (96x96)

Operating Instructions



EM306-C(96x96)

EM306(96x96)

FEATURES

- 6 digit 7 segment LED display.
- User programmable CT primary.
- Memory retention.
- Potential free Pulse output for energy.
- 90 to 270V AC/DC auxiliary supply.
- RS485 communication (MODBUS Protocol) (Applicable for EM306-C Only)

SPECIFICATIONS

DISPLAY

6 digit 7 segment LED display. Height 0.5"

LED INDICATIONS

INT - Integration of energy

X10 - Resolution is 10

REV - Reverse connected CT warning

INPUT

3 Ø - 4 wire and 1 Ø - 2 wire input type

RATED INPUT VOLTAGE

Nominal 300V AC max.

3-phases(R, Y, B) with respect to Neutral

FREQUENCY RANGE

50 Hz

RATED INPUT CURRENT

Nominal 6A maximum

CT PRIMARY

5 to 5000

BURDEN

0.5 VA @ 5A per phase

MEASUREMENT

kWh (resettable)

ACCURACY

Class 1

AUXILIARY SUPPLY RANGE

90 to 270V AC / DC, 50/60 Hz

OUTPUT

Pulse Output:

Voltage range - 24V DC

Current capacity - 100mA max

Pulse Width:

500 ms ± 50 ms.

RESOLUTION

| CT Primary | kWh | INT blink (kWh/blink) | Pulse output (kWh/pulse) |
|------------------------|------|-----------------------|--------------------------|
| ≤10 | 0.01 | 0.001 | 0.01 |
| 10 > CT primary ≤100 | 0.1 | 0.01 | 0.1 |
| 100 > CT primary ≤1000 | 1 | 0.1 | 1 |
| >1000 | 10 | 1 | 10 |

NOTE : Auto shift of resolution after display reaches maximum display point. For example resolution is shifted to 1 after 99999.9 kWh. After 999999 with resolution of 10 display rolls back to 0 and resolution shifts as per CT primary selected.

TEMPERATURE : Operating : 0 to 50 °C
Storage : -20 to 75 °C

HUMIDITY : 85% non-condensing

MOUNTING : Panel mounting

WEIGHT : 225 gms

SERIAL COMMUNICATION (Applicable for EM306-C Only)

| | |
|------------------------------------------|--------------------------------------------------|
| Interface standard & protocol | RS485 & MODBUS RTU |
| Communication address | 1 to 255 |
| Transmission mode | Half duplex |
| Data types | Float and Integer |
| Transmission distance | 500 m maximum |
| Transmission speed | 300, 600, 1200, 2400, 4800, 9600, 19200 (in bps) |
| Parity | None, Odd, Even |
| Stop bits | 1 or 2 |
| Response time | 100 ms (max and independent of baud rate) |

SAFETY PRECAUTIONS

All safety related codifications; symbols and instructions that appear in this operating manual or on the equipment must be strictly followed to ensure the safety of the operating personnel as well as the instrument.

If the equipment is not handled in a manner specified by the manufacturer it might impair the protection provided by the equipment.

CAUTION: Read complete instructions prior to installation and operation of the unit.

CAUTION: Risk of electric shock.

WIRING GUIDELINES

WARNING:

- To prevent the risk of electric shock power supply to the equipment must be kept OFF while doing the wiring arrangement.
- Wiring shall be done strictly according to the terminal layout. Confirm that all connections are correct.
- Use lugged terminals.
- To eliminate electromagnetic interference use of wires with adequate ratings and twists of the same in equal size shall be made.
- Cable used for connection to power source, must have a cross section of 1.5mm². These wires shall have current carrying capacity of 5A.

MAINTENANCE

- The equipment should be cleaned regularly to avoid blockage of ventilating parts.
- Clean the equipment with a clean soft cloth. Do not use Isopropyl alcohol or any other cleaning agent.

INSTALLATION GUIDELINES

CAUTION:

- This equipment, being built-in-type, normally becomes a part of main control panel and in such case the terminals do not remain accessible to the end user after installation and internal wiring.
- Conductors must not come in contact with the internal circuitry of the equipment or else it may lead to a safety hazard that may in turn endanger life or cause electrical shock to the operator.
- Circuit breaker or mains switch must be installed between power source and supply terminals to facilitate power 'ON' or 'OFF' function. However this switch or breaker must be installed in a convenient position normally accessible to the operator.
- Before disconnecting the secondary of the external current transformer from the equipment, make sure that the current transformer is short circuited to avoid risk of electrical shock and injury.

CAUTION:

- The equipment shall not be installed in environmental conditions other than those mentioned in this manual.
- The equipment does not have a built-in-type fuse. Installation of external fuse of rating 275VAC/1Amp for electrical circuitry is highly recommended.
- Thermal dissipation of equipment is met through ventilation holes provided on chassis of equipment. Such ventilation holes shall not be obstructed else it can lead to a safety hazard.
- Connectors screws must be tightened after Installation.

MECHANICAL INSTALLATION

EM306/EM306-C

For installing the meter

- Prepare the panel cutout with proper dimensions as shown below :

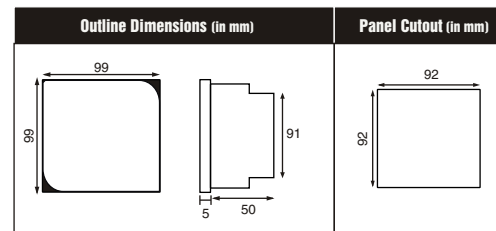

- Push the meter into the panel cutout. Secure the meter in its place by pushing the clamp on the rear side. The screws, of the pane of the clamp, must be in the farthest forward slot.
- For proper sealing, tighten the screws evenly with required torque.

CAUTION :

The equipment in its installed state must not come in close proximity to any heating sources, caustic vapors, oils, steam, or other unwanted process by-products.

EMC Guidelines:

- Use proper input power cables with shortest connections and twisted type
- Layout of connecting cables shall be away from any internal EMI source.

TERMINAL CONNECTIONS

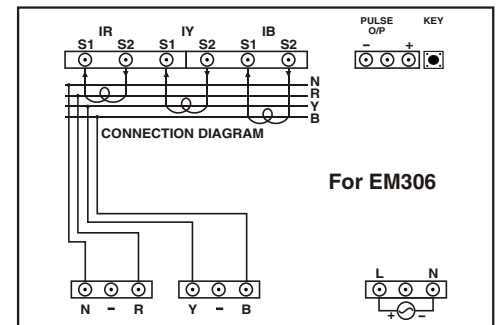
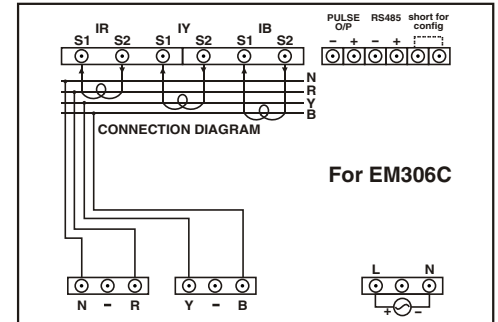

FRONT PANEL DESCRIPTION

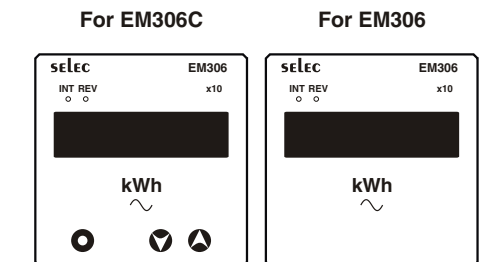

LED INDICATIONS

- INT : LED blinks when integration of energy is in progress.
- X10 : LED is ON when the resolution is 10
- REV: LED ON when there is improper wiring or negative power consideration in any or all phases.

PROGRAMMING SCHEME FOR EM306

The unit can be programmed using the 'tact key' near the terminals. The position of the key is as shown in terminal diagram.

To enter into Programming keep the key continuously pressed and power ON.

To configure CT primary

| Keys description | Display shows |
|---------------------|---------------|
| Press and power ON | |

Press the to scroll to the next CT value from the range. When key is pressed & released the value is modified. After last value it rolls back to the first value.

Following are the primary ranges:

5, 30, 40, 50, 60, 75, 80, 100, 150, 200, 250, 300, 400, 500, 600, 800, 1000, 1200, 1500, 1600, 2000, 2500, 3000, 4000, 5000.

NOTE: Key has no other function during normal working mode.

CONFIGURATION SCHEME FOR EM306-C

(parameter setting)

To enter configuration : Short terminals marked as **short for config**

| Key press | Display | Description |
|-----------------------------------------------------------|---------|---------------------------------------------------------|
| 1. To enter configuration menu Factory setting: 25 | | |
| Display | | Range: 0 to 999 |
| Press / | | key to change values |
| Press | | key to access next parameters |
| 2. CT ratio Factory setting: 5 | | |
| Display | | Range: 5 to 5000 |
| Press / | | key to change values |
| Press | | key to access next parameters |
| 3. Slave ID Factory setting: 1 | | |
| Display | | Range: 1 to 255 |
| Press / | | key to change values |
| Press | | key to access next parameters |
| 4. Baud rate Factory setting: 9600 | | |
| Display | | Range: 300, 600, 1200, 2400, 4800, 9600, 19200 (in bps) |
| Press / | | key to change values |
| Press | | key to access next parameters |
| 5. Parity Factory setting: NO | | |
| Display | | Range: None, even, odd |
| Press / | | key to change values |
| Press | | key to access next parameters |

6. Stop bit

Factory setting: 1

Display

Range: 1 or 2

Press / key to change values

Press key to access next parameters

7. Password for Energy Reset

Factory setting: 1000

Display

Press / Range: 0 or 9999

Press key to access next parameters

8. Energy Reset

Factory setting: NO

Display

Range: No / Yes

Press / key to change values

Press key to access next parameter

Note:- Upon enabling the front reset feature, user should be able to reset the energy by pressing key for 3 sec. after coming out of configuration

Exit configuration mode:

Do not press any key for 30 sec in configuration mode. or

Power OFF and power ON unit again after removing "Short for config"

APPLICATION OF PULSE OUTPUT

● PROCESS INTEGRATION

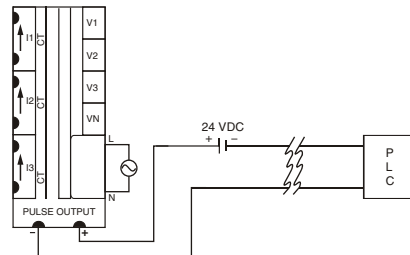

Pulse output from EM306 meter can be interfaced into a process through a PLC for on line control of energy content in the process.

If the PLC has a self excited 24V digital input, external 24V DC supply is not needed.

The kWh pulse is also used to derive average kWh information at the PLC.

USER GUIDE

What does the INT, REV and X10 LEDs on the front panel indicate ?

● **INT:** The INT LED provides quick visual indication of energy integration. The blink rate is 10 times per count update and it is depending upon the CT primary. By running at faster rate, the user need not wait long till the counter up dation in the meter.

● **X10:** X10 LED ON when the resolution is 10. It is the indication of count reading which must be multiplied by 10 to get actual kWh consumed.

● **REV:** REV LED gives the indication of reversal of two or more CT connections. In such cases meter may not indicate the correct energy consumption. The CT should be connected to the meter with correct polarities.

NOTE :

- 1) In configuration menu repeated pressing of key will allow toggling between all the configuration parameters
- 2) In configuration menu only after pressing key will the new values of every configurable parameter be updated

TYPICAL WIRING DIAGRAM

3 PHASE 4-WIRE

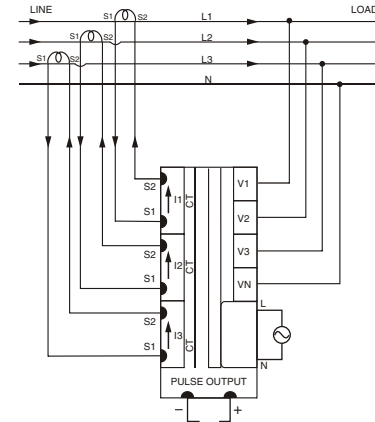

SINGLE PHASE

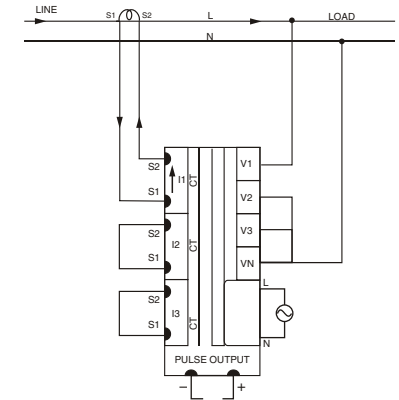

MODBUS register addresses list (Applicable for EM306-C Only)

| Readable parameters from master | | | | | |
|---------------------------------|-----------|-----------|---------------|-------------------|----------------|
| Address | Parameter | Range | | Length (Register) | Data Structure |
| | | Min value | Maximum value | | |
| 30000 | kWh | 0 | 9999999 | 2 | Float |

| Writable parameters from master | | | | | |
|---------------------------------|-------------|-----------|---------------|-------------------|----------------|
| Address | Parameter | Range | | Length (Register) | Data Structure |
| | | Min value | Maximum value | | |
| 40000 | CT primary | 5 | 5000 | 1 | Integer |
| 40001 | Slave ID | 1 | 255 | 1 | Integer |
| 40002 | Baud rate | Value | Baud rate | 1 | Integer |
| | | 0X0000 | 300 | | |
| | | 0X0001 | 600 | | |
| | | 0X0002 | 1200 | | |
| | | 0X0003 | 2400 | | |
| | | 0X0004 | 4800 | | |
| | | 0X0005 | 9600 | | |
| | | 0X0006 | 19200 | | |
| 40003 | Parity | Value | Parity | 1 | Integer |
| | | 0X0000 | None | | |
| | | 0X0001 | Even | | |
| | | 0X0002 | Odd | | |
| 40004 | Stop bit | Value | Stop bit | 1 | Integer |
| | | 0X0000 | 1 | | |
| | | 0X0001 | 2 | | |
| 40005 | Front reset | Value | Front reset | 1 | Integer |
| | | 0X0000 | Disable | | |
| | | 0X0001 | Enable | | |
| 40006 | Reset kWh | Value | kWh Reset | 1 | Integer |
| | | 0X0000 | No | | |
| | | 0X0001 | Yes | | |

Selec Controls Pvt. Ltd.

(Specifications are subject to change, since development is a continuous process)

Telephone: +91-22-40394200 / 40394202

Fax: +91-22-28471733

Toll free: 1800 227 353

Website: www.selec.com

Email: sales@selec.com